

# BOX LADDER

## Assembly Instructions

Please read this instruction completely before beginning assembly. Carefully remove all parts from the box and identify them from the parts list. Always wear ANSI approved safety goggles when working with tools and equipment. Please have all hardware installed loose and not tightened until everything is installed and make sure all legs touch floor firmly, then tighten everything together and make sure nothing is forced into place.

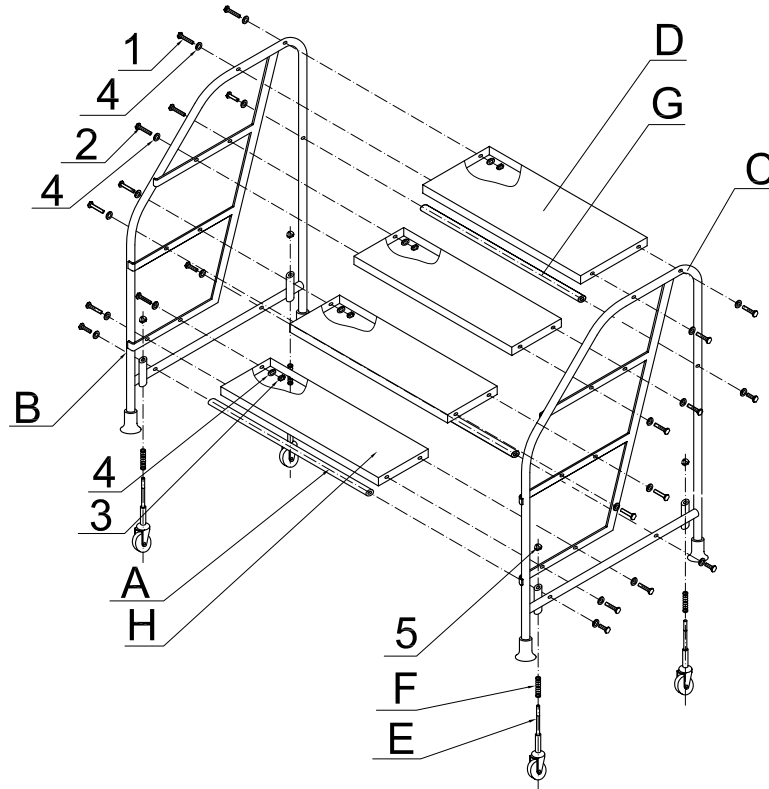

REP	DESCRIPTION	1step	2steps	3steps	4steps	REP	DESCRIPTION	1step	2steps	3steps	4steps
		QTY						QTY			
A	LONGER CONNECTING PIPE		2pcs	2pcs	2pcs	H	STEP		1pc	2pcs	3pcs
B	LEFT LEG	1pc	1pc	1pc	1pc	1	BOLT-M8x45	4pcs	4pcs	4pcs	4pcs
C	RIGHT LEG	1pc	1pc	1pc	1pc	2	BOLT-PERFORATED TREAD STEP-M8x20 OR EXPANDED METAL TREAD STEP-M8x25		4pcs	8pcs	12pcs
D	TOP STEP	1pc	1pc	1pc	1pc						
E	CASTOR2"	4pcs	4pcs	4pcs	4pcs	3	NYLON LOCK NUT -M8	4pcs	8pcs	12pcs	16pcs
F	SPRING	4pcs	4pcs	4pcs	4pcs	4	FLAT WASHER	8pcs	16pcs	24pcs	32pcs
G	SHORTER CONNECTING PIPE	1pc	1pc	1pc	1pc	5	CAP LOCK NUT M8	4pcs	4pcs	4pcs	4pcs

- STEP1:** Pick out the shorter connecting pipe (G) from the three connecting pipes and attach it to the left leg (B) and the right leg (C) on the rear side of the ladder as shown in the diagram using bolts-M8x40 and lock washers.(1 step excepted)
- STEP2:** Repeat step 1 with the other two connecting pipes (of the same length ) on the bottom of the ladder. (1 step ladder has only one connecting pipe with bolts M8x25)
- STEP3:** Assemble the top step (H) to the left leg and the right leg with bolts-M8x45 (1) the other steps with bolts- M8x20 (2) (bolts-M8x25 will be used in case of expanded metal tread step), flat washers (4) and nylon lock nuts-M8 (3)
- STEP4:** Assemble the 2" castors (E) and springs (F) to the base bar and lock the castors by cap lock nut (5)

This Assembly instruction is used for one , two, three and four steps ladder.