

ML123221

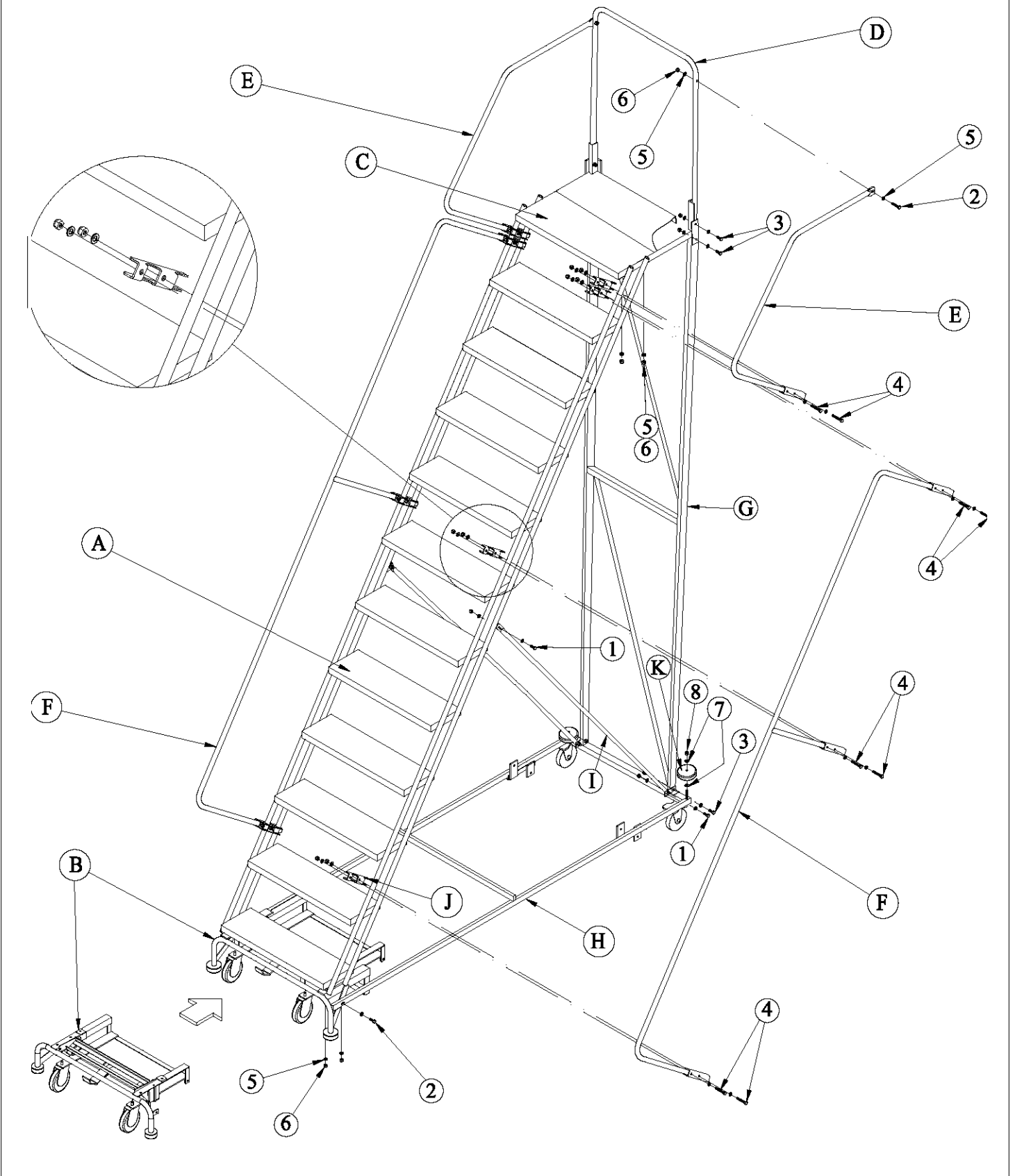

Inspect the ladder for shipping damage prior to starting assembly. If there is evidence of shipping damage notify the carrier immediately.

STEP 1 - ASSEMBLE TOP STEP

- Place Stair Section (A) face down and attach Top Step (C) using four washers (5) and locknuts (6). Tighten bolts completely.

STEP 2 - ATTACH LOCKSTEP

- Attach Lockstep (B) to the bottom step using four washers (5) and locknuts (6). Tighten bolts completely.

STEP 3 - ATTACH VERTICAL WELDMENT

- Place Vertical Weldment (G) onto back of Top Step (C) and align Vertical Weldment (G) with Angle which is welded on corner of the Top Step (C) use M8 x 45 bolts (3) with washers (5) and locknuts (6).
- Do not tighten bolts.

STEP 4 - ATTACH BASE WELDMENT

- Align Base Weldment (H) with the Tabs on the Lockstep(B). Note; The casters point up for this alignment.
- Use two M8 x 40 bolts (2) with washers (5), and locknuts (6) to fasten the Base Weldment (H) to the Front Legs. Do not tighten.

STEP 5 - CONNECT BASE WELDMENT AND REAR VERTICAL WELDMENTS

- Lay the ladder on its side; align the hole in the Tabs on the Base Weldment with the hole in the lower ends of the vertical Weldment and bolt together using M8 X 45 bolts (3) with washers (5) and locknuts (6). Take care not to over tighten.

If you purchased the All Directional Option install it now, follow the directions included with your kit when complete return to step 6

STEP 6 - INSTALL BRACES

- Install Diagonal Braces (I) using M8x20 bolts (1) with washer (5) and locknut (6). Note: this brace runs from the Tabs on the Base Weldment to the Stair Section (A).

Get assistance to stand the ladder up. Once the ladder is standing take it to a flat surface. Release the lock step dropping front legs of the ladder to the ground. Make sure the ladder is firmly on the ground and tighten all bolts.

STEP 7 - ASSEMBLE HANDRAIL CONFIGURATION – BE CAREFUL WHEN ASSEMBLING HANDRAIL – WE RECOMMEND A SPOTTER TO ASSIST IN THIS STEP

- Bolt Rear Guardrail (D) to the Top Step (C) using M8 x 45 bolts (3), washers (5) and locknuts (6).
- Connect Top Handrails (E) to Rear Guardrail (D) using M8 x40 bolts (2), washers (5) and locknuts (6).
- Attach Handrail Bracket (J) to the Top Handrail (E) using M8 x 55 bolts (4), washers (5) and locknuts (6). Note: Handrail Brackets (J) should be positioned on the inside of Stair Section (A). Confirm Rear Guardrail (D) is perpendicular to the Top Step (C), and tighten the bolts.
- Mount Lower Handrails (F) using Handrail Brackets (J) and M8 x 55 bolts (4) and washers (5), and locknuts (6). Note: Top of Lower Handrail should butt against Top Handrail.
- Tighten all hardware.

STEP 8 – INSTALL THE BUMPER WHEEL

- Install the bumper wheel (K) with washers (7) and locknuts M10 (8). Make sure the bumper wheels spin properly after installation.

STEP 9 - FINAL INSPECTION

- Check to see that ladder sits level on floor. After confirming that ladder sits level, tighten all hardware. Confirm all bolts have been properly tightened.
- Read instruction manual and become familiar with proper usage and maintenance.
- Connect instruction manual to the ladder; insure all users read important safety information.

STEP 10 LOCK STEP ADJUSTMENT

- your lock step has be preset at the factory to release when a 70 lbs load is applied to the stair section. It may be desirable for the release load to be increased or decreased due to working environment. To adjust tighten (increases load required to release the lock step) or loosen (decreases load required to release the lock step) the bolt which goes through the compression springs on both sided of the lock step. Please note adjustment is sensitive, test frequently.

PARTS LIST

<u>PART #</u>	<u>DESCRIPTION</u>	<u>QUANTITY</u>
A	STAIR SECTION	1
B	LOCKSTEP	1
C	TOP STEP	1
D	REAR GUARDRAIL	1
E	TOP HANDRAIL	2
F	LOWER HANDRAIL	2
G	VERTICAL WELDMENT	1
H	BASE WELDMENT	1
I	DIAGONAL BRACE	2
J	HANDRAIL BRACKET	6
K	BUMPER WHEEL	2
1	<i>BOLT M8 X 20</i>	4
2	<i>BOLT M8 X 40</i>	4
3	<i>BOLT M8 X 45</i>	6
4	<i>BOLT M8 X 55</i>	12
5	<i>WASHER Ø 8</i>	60
6	<i>LOCKNUT M8</i>	34
7	<i>WASHER Ø 10</i>	4
8	<i>LOCKNUT M10</i>	2